



LBC 3094/15 Sound Projector



- ▶ Suitable for speech and music reproduction
- ▶ Simple power setting
- ▶ 2 m fixed connection cable
- ▶ Splash-waterproof
- ▶ Robust self-extinguishing ABS enclosure to UL 94 V0
- ▶ Complies with international installation and safety regulations

The LBC 3094/15 is a sound projector for speech and music reproduction in indoor or outdoor applications such as shopping centers, factory grounds and sports fields.

Functions

Sound projectors are intended for applications where directing the sound beam is desirable. Similar in concept to a spotlight, a sound projector can be used to provide localized sound reproduction. Typical examples include restaurants, exhibitions, factory grounds and shopping centers.

The sound projectors are splash waterproof and suitable for outdoor use and in environments with high humidity levels such as swimming pools.

The enclosures are made from high-impact self-extinguishing ABS (acc. to class UL 94 V0). The sound projector enclosures are colored off-white and supplied with steel mounting brackets painted in off-white. They are suitable for mounting onto walls or ceilings.

Certifications and Approvals

All Bosch loudspeakers are designed to withstand operating at their rated power for 100 hours in accordance with IEC 268-5 Power Handling Capacity (PHC) standards. Bosch has also developed the Simulated Acoustical Feedback Exposure (SAFE) test to demonstrate that they can withstand two times their rated power for short durations. This ensures extra reliability under extreme conditions, leading to higher customer satisfaction, longer operating life, and much less chance of failure or performance deterioration.

All plastic parts are manufactured from self-extinguishing high-impact ABS material (according to UL 94 V0). In common with all Bosch products, care is taken to meet high safety standards. These sound projectors comply with all the relevant safety and installation regulations of EN 60065.

Region	Certification
Europe	CE
Water and dust protection	acc. to EN 60529, IP 63

Installation/Configuration Notes

All units are supplied with a color-coded four-core connecting cable with each color connected to a different primary tap on the 100 V matching transformer. This allows nominal full-power, half-power or quarter-power radiation to be selected (in 3 dB steps).

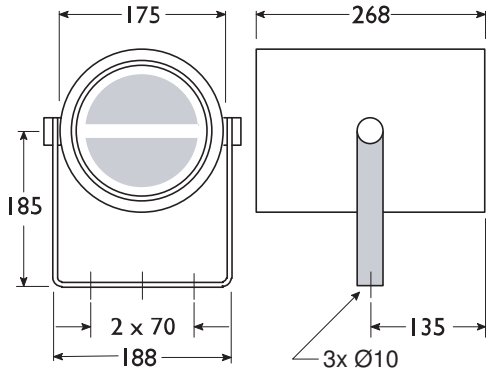

Dimensions in mm

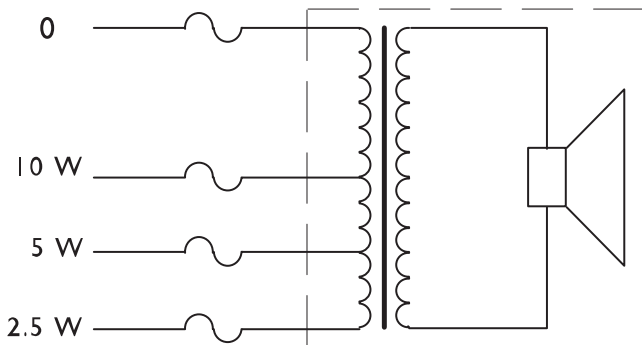

Circuit diagram

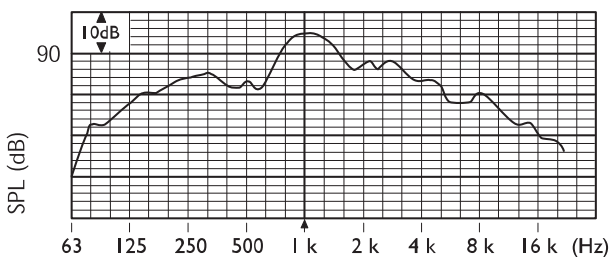

Frequency response

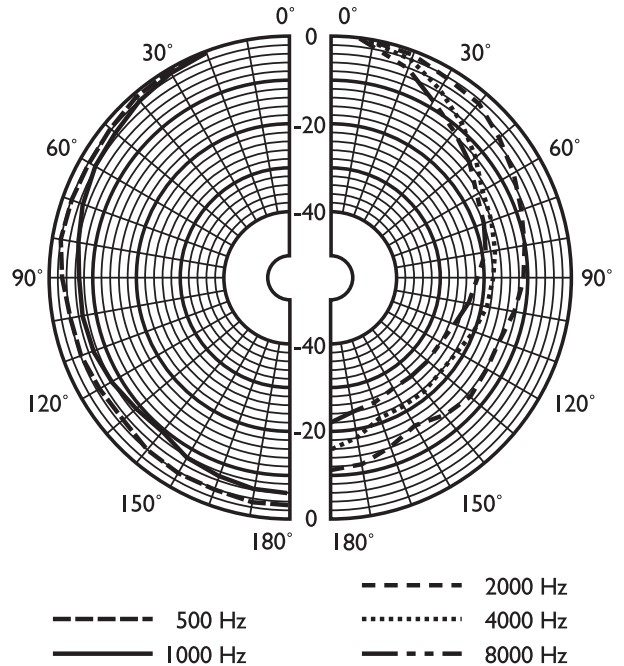

Polar diagram (measured with pink noise)

	125 Hz	250 Hz	500 Hz	1 kHz	2 kHz	4 kHz	8 kHz
SPL 1.1	81	82	85	92	89	87	79
SPL max.	91	92	95	102	99	97	89
Q-factor	1.2	1.3	1.8	3.1	5.9	20	32
Efficiency	0.1	0.1	0.2	0.6	0.2	0.03	0.01
H. angle	360	360	360	160	105	70	40
V. angle	360	360	360	160	105	70	40

Acoustical performance specified per octave

Technical Specifications

Electrical*

Maximum power	15 W
Rated power	10 / 5 / 2.5 W
Sound pressure level at 10 W / 1 W (1 kHz, 1 m)	102 dB / 92 dB (SPL)
Effective frequency range (-10 dB)	140 Hz to 13 kHz
Opening angle at 1 kHz / 4 kHz (-6 dB)	160° / 70°
Rated voltage	100 V
Rated impedance	1000 ohm
Connection	2 m 4-wire cable

* Technical performance data acc. to IEC 60268-5

Mechanical

Dimensions (D x L)	175 x 268 mm (6.9 x 10.5 in)
Weight	2.5 kg (7.3 lb)
Color	Off white (RAL 9001)

Environmental

Operating temperature	-25 °C to +55 °C (-13 °F to +131 °F)
Storage temperature	-40 °C to +70 °C (-40 °F to +158 °F)
Relative humidity	<95%

Ordering Information

LBC 3094/15 Sound Projector 10 W, white ABS	LBC3094/15
---	-------------------

Accessories

LBC 1256/00 EVAC Connection Adapter 3-pole screw connector, 100 pieces	LBC1256/00
--	-------------------

Americas:
Bosch Security Systems, Inc.
130 Perinton Parkway
Fairport, New York, 14450, USA
Phone: +1 800 289 0096
Fax: +1 585 223 9180
security.sales@us.bosch.com
www.boschsecurity.us

Europe, Middle East, Africa:
Bosch Security Systems B.V.
P.O. Box 80002
5600 JB Eindhoven, The Netherlands
Phone: + 31 40 2577 284
Fax: +31 40 2577 330
emea.securitysystems@bosch.com
www.boschsecurity.com

Asia-Pacific:
Robert Bosch (SEA) Pte Ltd, Security Systems
11 Bishan Street 21
Singapore 573943
Phone: +65 6258 5511
Fax: +65 6571 2698
apr.securitysystems@bosch.com
www.boschsecurity.com

Represented by